



**BETTER WITHOUT
CYLINDER**

The **HKS**
CONSTRUCTION TECHNOLOGY



Exactly the right thing for professionals: precise spatial positioning saves time and costs.

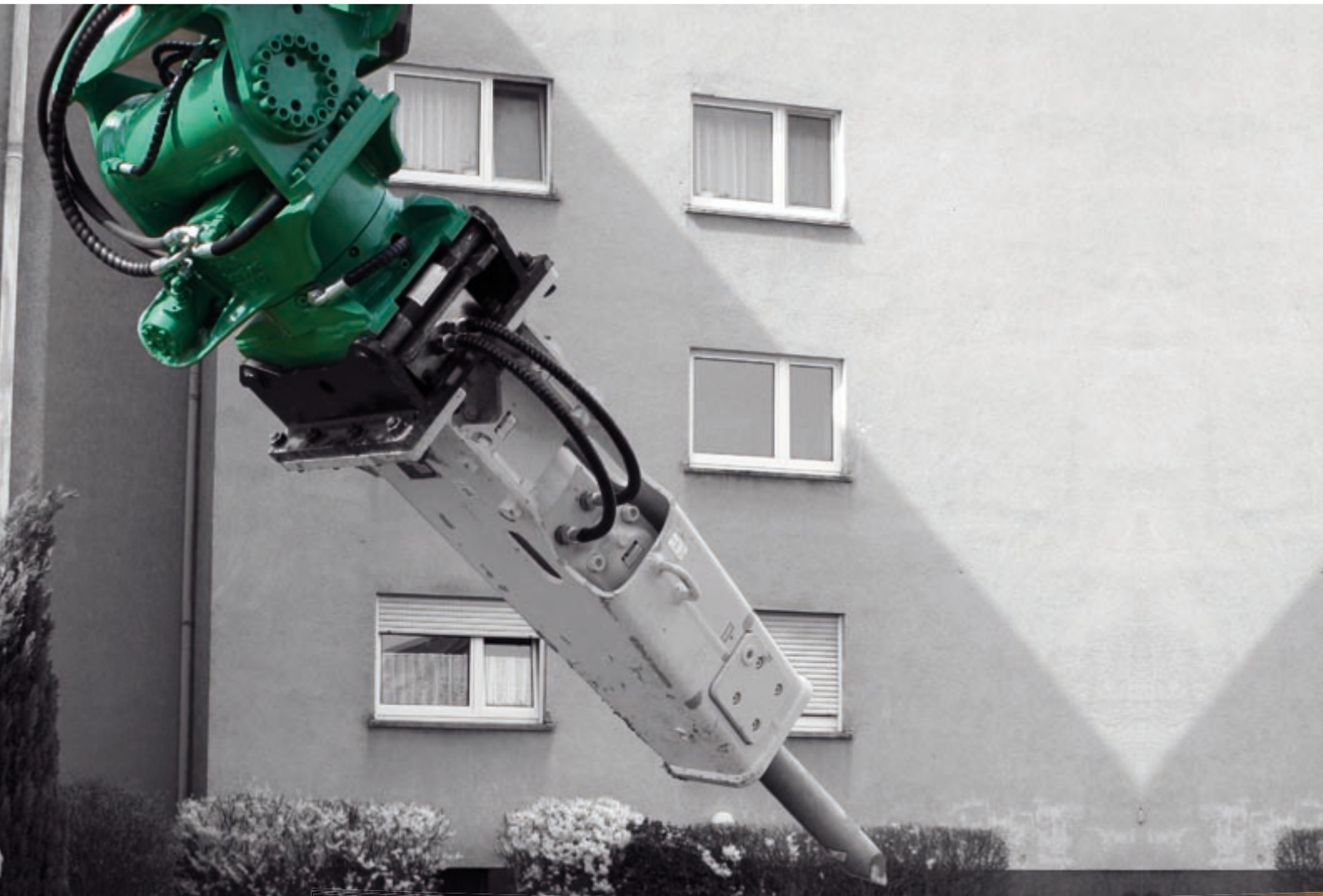

We **tilt** your **attachments** and **shovel devices** up to **180°** and/or let them **endlessly rotate** left/right

With products of the **HKS Construction Technology** you increase the productivity of your attachments and your hydraulic excavator is turned into a multifunctional machine. The extended operating range of your attachment allows a wide variety of work to be carried out more quickly, accurately and efficiently. For each application we offer the demand-oriented solution.

We offer to you

- + increased productivity of up to 40%
- + a modular system
- + own development and production, 100% Made in Germany
- + precise tilting and positioning without cylinder
- + compatibility with **all** conventional quick-change systems and hydraulic excavators up to 100t
- + financing possibilities

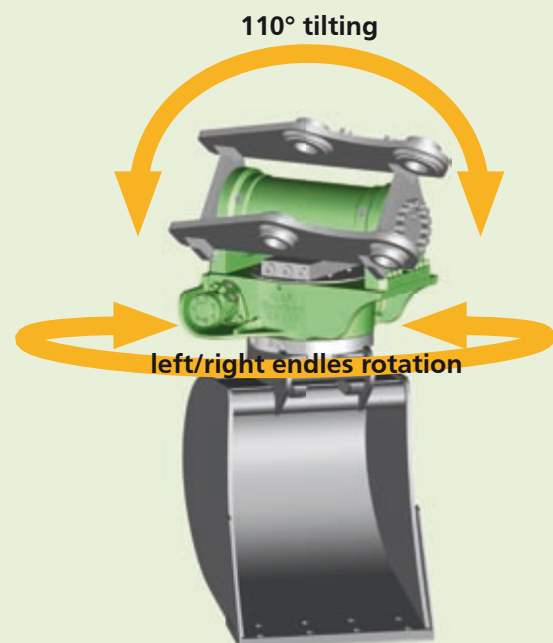

EXPERIENCE MORE

For each application we offer the tailored product.

HKS XtraTilt

tilts and positions
up to 100°, 140° or 180°

- » Horticultural and agricultural work
- » Embankment work
- » Excavation work
- » Demolition work / ripper tooth
- » Underground work / road building
- » Building backfills
- » Foundation work
- » Dosing work
- » Soil excavation
- » Work on sloping surfaces
- » Hydraulic hammer insert

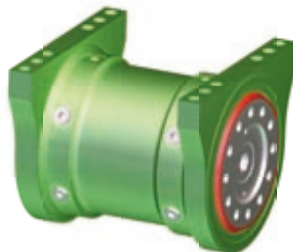

Rotatable trench shovel with XtraTilt

HKS RotoBox

left/right endless rotation in both
directions with oil feedthrough

- » Horticultural and agricultural work
- » Excavation work
- » Demolition work
- » Underground work / road building
- » Building backfills
- » Foundation work
- » Canal work
- » Trenching



RotoBox in use

Combines all applications*

The **HKS TiltRotator** can be broken down into its individual modules and used separately at any time.

HKS TiltRotator

simultaneous tilting
and rotating



TiltRotator in use

*for hammer and milling cutter application, long-term studies are not available so far. We kindly ask for your understanding that we can therefore assume only a limited warranty at the present time.



Hammer insert with XtraTilt

High tip bucket without cylinder with **HKS Xtratilt**



Grab with RotoBox

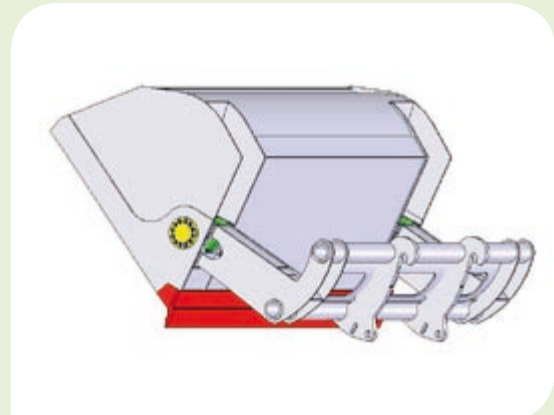

HKS TiltRotator with a milling cutter at the bauma 2010

- ⊕ Maintenance-free operation without play
- ⊕ Optimal tube guidance, as tubes are placed inside the frame
- ⊕ Excellent torque qualities
- ⊕ Up to three times the lifting and dumping speed as compared to cylinders
- ⊕ Low space requirements for installation
- ⊕ System-protected



BETTER WITHOUT CYLINDER

HKS XtraTilt

tilt up to 180°

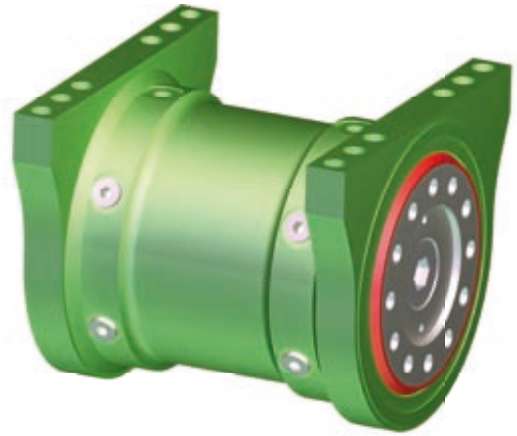

Longstanding experience and innovation have made it possible to make our BVC Power Actuator even stronger, more powerful and robust. Here it is: the **HKS XtraTilt**.

Owing to its compact 4-part design our **HKS XtraTilt** series are already factory protected from the penetration of dirt into the housing and need less maintenance.

For our customers that means:

- +** no relubrication
- +** no readjustment
- +** precise tilting and positioning without cylinder
- +** double sided actuator centring for supplementary power receiving
- +** special manufacturing, annealing and hardening processes give our robust welding housing maximum shape accuracy and protection against wear, tear and rust

— Shovel with linear cylinder

HKS XtraTilt

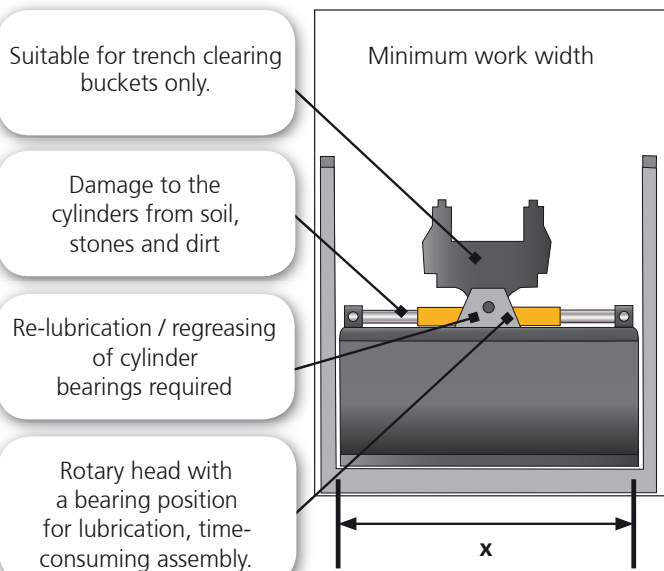

Suitable for trench clearing buckets only.

Damage to the cylinders from soil, stones and dirt

Re-lubrication / regreasing of cylinder bearings required

Rotary head with a bearing position for lubrication, time-consuming assembly.

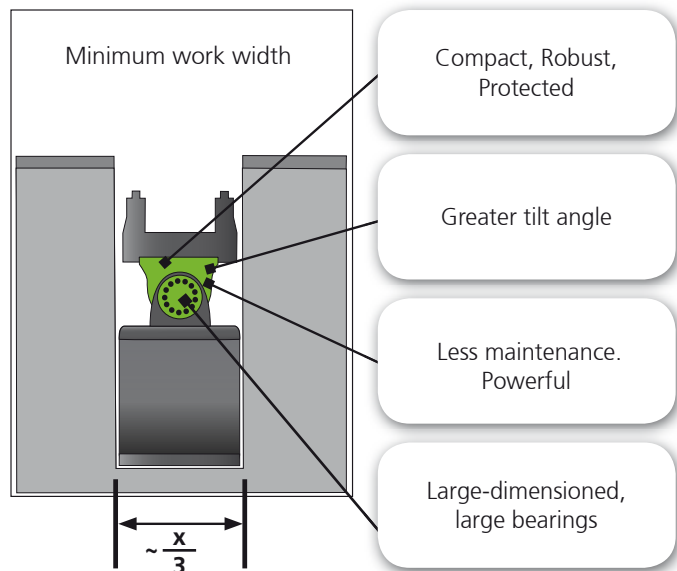

Compact, Robust, Protected

Greater tilt angle

Less maintenance. Powerful

Large-dimensioned, large bearings

Diagrammatic representation

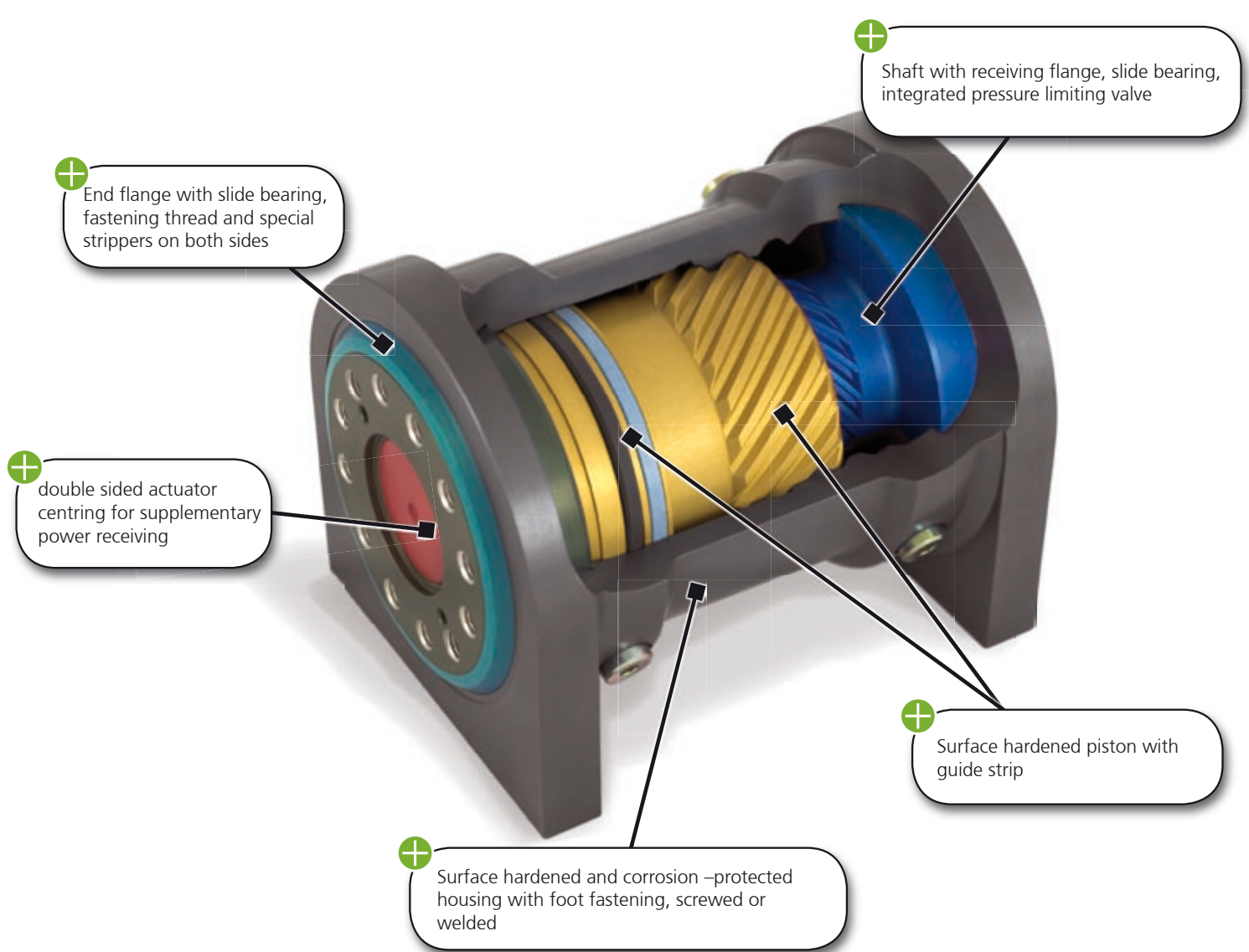

For rough everyday working conditions the right choice: thanks to its compact 4-part design, high-quality materials and precise manufacture ensure that the **HKS XtraTilt** is the most robust rotary actuator of its class.

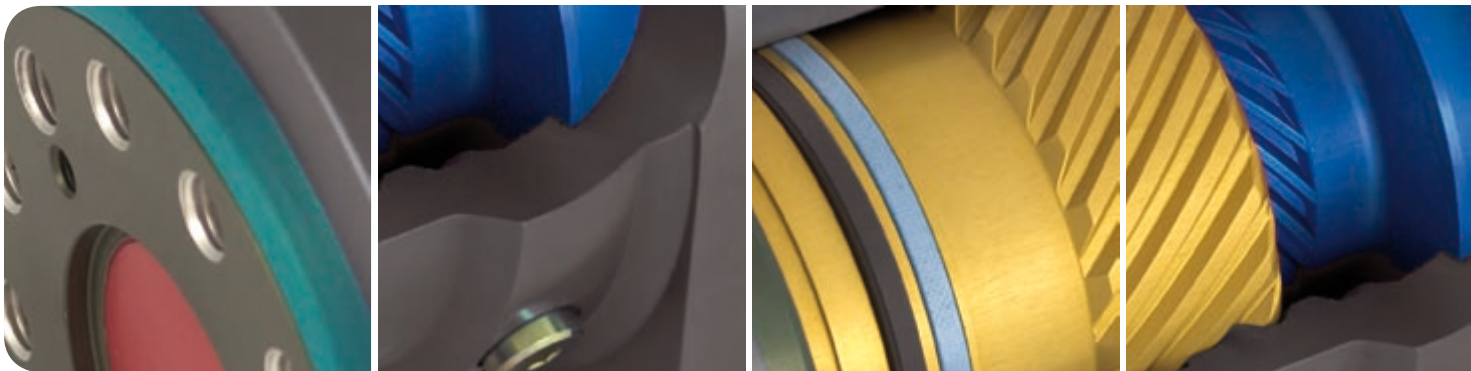

For us innovation means not only to design our actuators even stronger and more powerful, but also to develop promising products with respect to environmental efficiency. If desired, our actuators can also be operated with **biological service media**. This is made possible by sealing systems individually adjusted for this service media.

In one sentence:

With our **HKS XtraTilt** series you purchase a durable German quality product being the result of more than one decade of operational and design experience.



HKS RotoBox

Rotate attachments endlessly left/right

More flexibility for your attachments - with the **HKS RotoBox** you widen your operating range up to 360°. This enables a more flexible operating from a fix position and opens up new fields of applications.

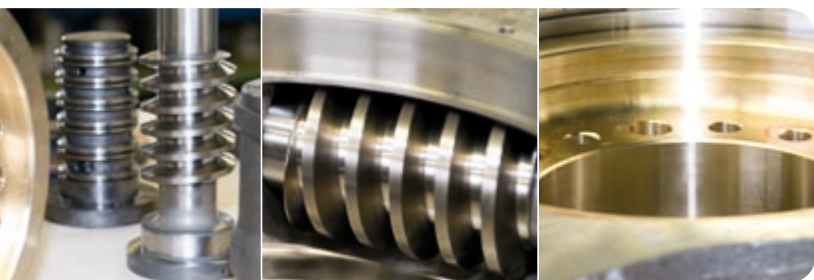

- + low structural height
- + self-locking
- + high-strength cast steel
- + worm drive running in oil

The **HKS RotoBox** is your entrance card to the spatial use of your buckets and attached implements. Thanks to the endless left/right rotation, you are already able to cover a large number of additional tasks in comparison to the tilt unit **HKS XtraTilt**. Should you wish to use your tools at 100% at a later point in time, this is not a problem either: the **HKS RotoBox** is capable of

being enlarged at any time by the tilt equipment **HKS XtraTilt-R**, which is optimised in terms of building height and torque.

Your advantage: the system grows with you and your requirements and tasks, reducing initial investment costs in line with your individual requirements.

Rotary Oil Feedthrough

up to 360l/min oil flow rate

Do you have hydraulic tools which require a great deal of oil for maximum performance?

With the extra large **HKS rotary oil feedthrough** attached hydraulic tools are fed with up to **360 l/min of oil**.

- + maximum performance for your attachments
- + wear-resistant parts



HKS TiltRotator

Simultaneous tilting and rotating



The **HKS TiltRotator** supports your hydraulic excavator with two new functions: The shovel can rotate endlessly and tilt up to ± 55 , if desired also up to ± 70 , in both directions.

The compact **HKS XtraTilt** as module of the **HKS TiltRotator** completely replaces the wider cylinder variant, liable to faults, with a maximum of $\pm 45^\circ$ tilt angle.

- +** increased productivity of up to 40%!
- +** modular system
- +** open up new fields of application
- +** fuel-saving thanks to extended operating range in upright position
- +** space-saving tilting and positioning without cylinder
- +** less crop damage
- +** working in very confined spaces possible

Proprietary Models



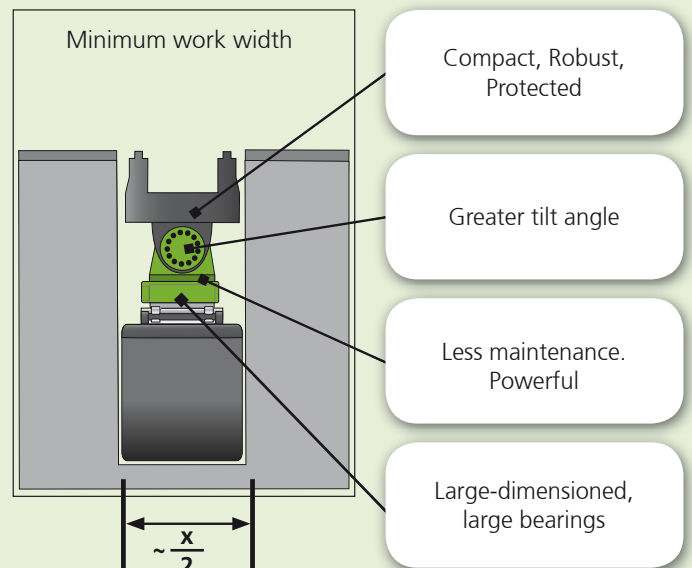
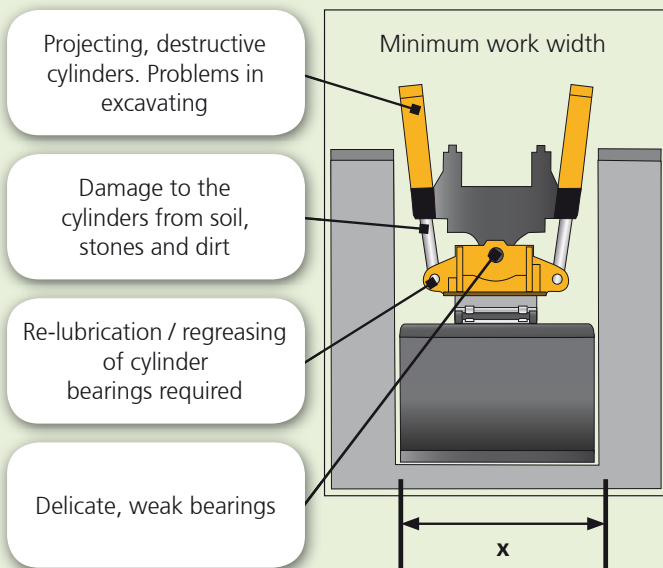



HKS TiltRotator

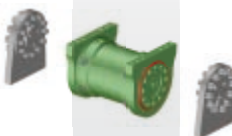

Diagrammatic representation

Modular design

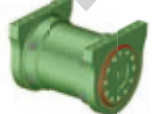
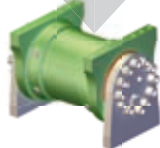
Super simple • Simply super

	HKS XtraTilt as single implement	HKS XtraTilt L-Variante with straps for direct mounting on the shovel	HKS XtraTilt K-Variante with fixed arm connection and quick-changer
Fixed arm connection (optional) Compatible with every excavator up to 100t Also welded			
HKS XtraTilt Available in 16 sizes up to 100t Tilt angle: 100°, 140° or 180° Holding torque up to 165,000 Nm From 19 kg <i>BETTER WITHOUT CYLINDER</i>			
Rotary oil feedthrough (optional) Up to 360 l/min flow rate (only for RotoBox)			
HKS RotoBox Available in 7 sizes from 1t up to 45t Torque up to 4,200 Nm Up to 8 U/min From 44 kg (with adapter plate)			
Quick-changer (optional) Compatible with every quick-changer			
			

Option: Welding connection consisting of fixed arm connection and XtraTilt for a more compact construction height.



Suitable for: **all** hydraulic excavators up to 100t
all quick-changers
all attachments

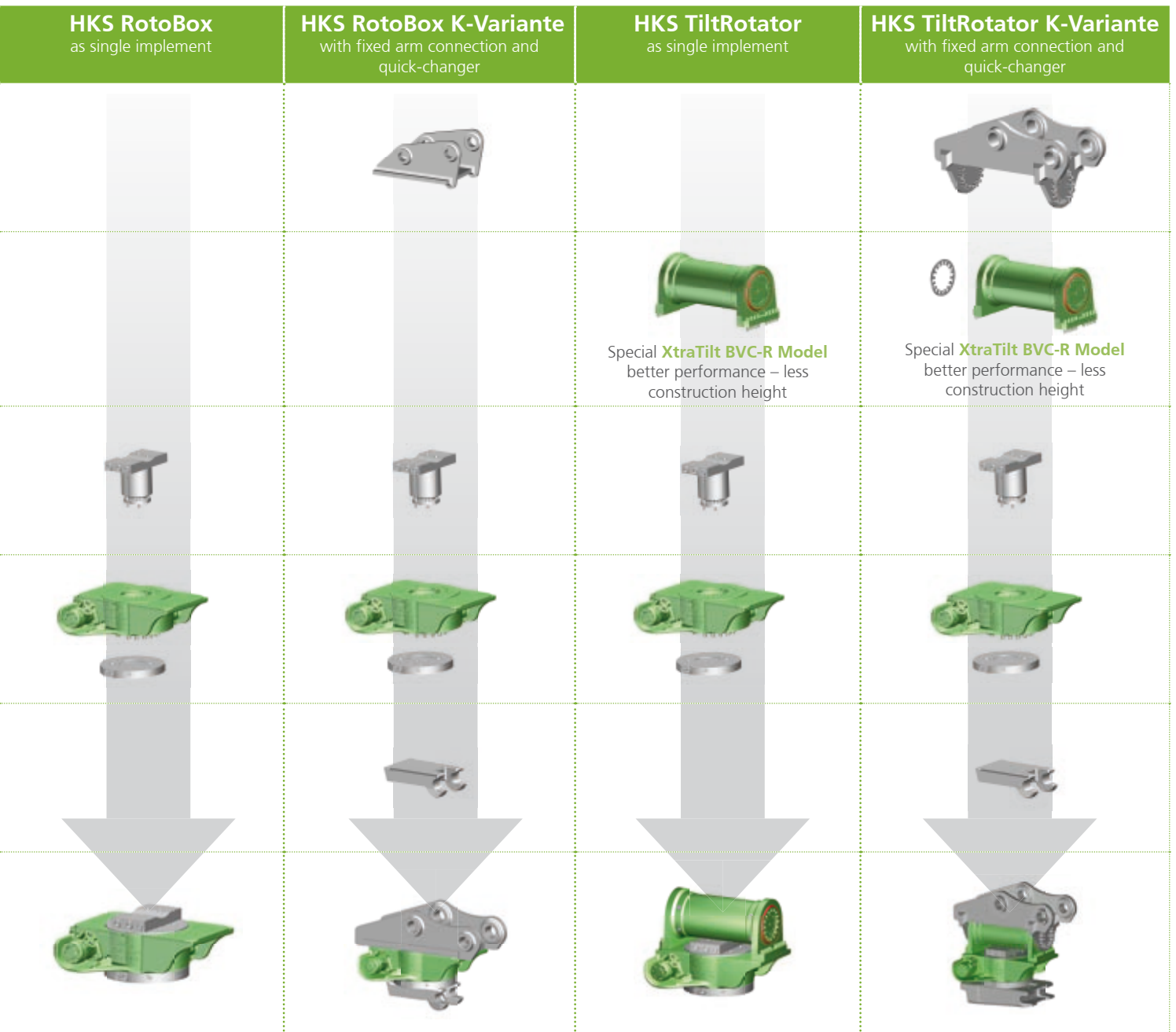



Wächtersbach



Neukirch/Lausitz

HKS stands for quality

Since 1970 there has only been one name in the field of hydraulic, pneumatic and mechanical components and systems on which you can rely on without compromise. HKS is your specialist in almost all industrial and mobile areas when it comes to innovations, quality, safety and performance.

At our two locations in Wächtersbach (Hesse) and Neukirch (Saxony) we develop, design and

produce to the highest level to meet your demands, without exception. Customers all over the world rely on our extremely dependable products and, that way, have turned us into the world market leader in this field.

Thus the originally two-men-company has become a Group with over 130 employees over the last 40 years.

Made in
Germany



Test bench with RotoBox and XtraTilt

Service

The manufacturing is subject to strict quality controls. Every actuator is tested on our test bench through its paces. Only an actuator matching up to our ideas of quality and precision will leave our factory.

Nevertheless, should you have a problem with one of our actuators it is our aim to provide you with a substitute within 24 hours in order to keep your downtime as short as possible.



HKS control system

Precision engineering also requires precision control. HKS therefore supplies for its products a high performance electrical control unit which provides optimum support, for example, for the functions of the TiltRotator. With the **HKS control system** you can tilt and rotate, operate your quick couplers and control your attachment – all at the same time and all at the press of a button.

In the case of the **HKS control system** our developers have also given consideration to maximum system flexibility:

- + The control unit and cable set can easily be installed without interfering with the on-board electrics, but they can also be incorporated in the existing electrical system by a specialist workshop if required.
- + The control system makes use of the existing hydraulic installation in the basic machine. No new installation necessary!
- + Suitable for all hydraulic excavators with an on-board voltage of 12-24V.

HKS TiltRotator



With the optimum control system working with your **HKS TiltRotator** will as simple as it were your extended arm.

Cable set



Complete cable set for outdoor and indoor installation, including all the connecting plugs and switches for simple, fast installation of the electrics.

Control unit



Connecting plugs protected from pole reversal and solid design guarantee simple, fast assembly of the control unit. The stable plastic housing protects against dust and dirt and is also short-circuit resistant.

Function keys...



With six function keys for direct mounting on pre-installed joysticks.

or joystick



The joystick, wired with highly flexible single conductors, can be fitted with up to six pressure switches and can be perfectly adapted to the applicable requirements. It also sits well in the hand due to its ergonomic shape.

HKS XtraTilt • Technical Data

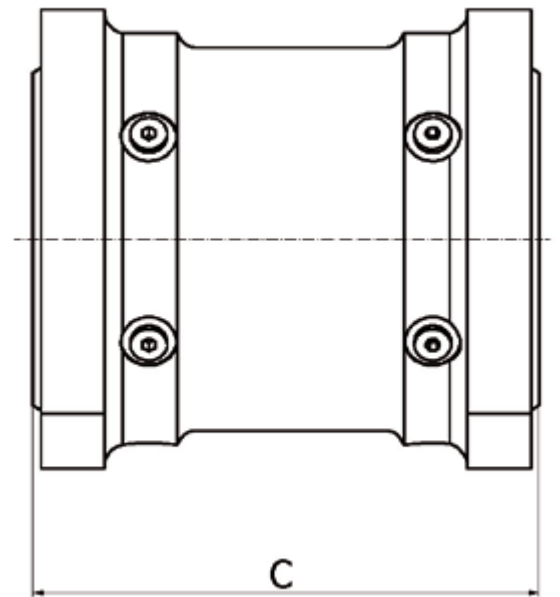
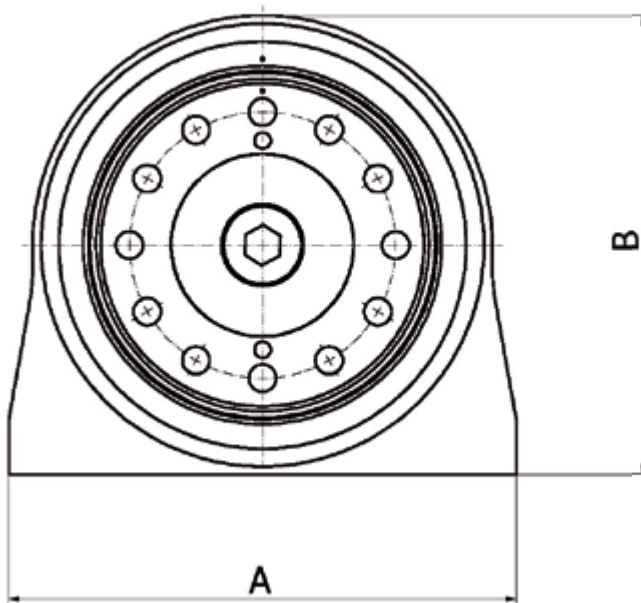
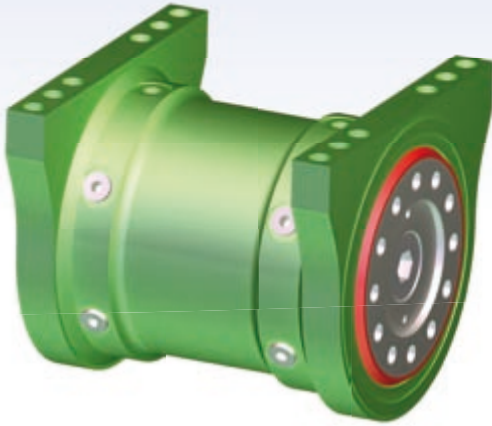

Excavator weight [t]	XtraTilt Type	Tilt angle	Holding torque [Nm]	Working pressure [bar]	Displacement [dm ³]	Weight [kg]	Dimensions		
							A [mm]	B [mm]	C [mm]
< 1,8	BVC 100	100°	2.480	190	0,18	19	150	152	197
		140°			0,25	21			221
		180°			0,323	22			245
1,8 - 3,8	BVC 115	100°	7.300	190	0,284	42	220	187	264
		140°			0,399	47			306
		180°			0,513	52			344
3 - 5,5	BVC 125	100°	7.800	190	0,385	51	220	212	267
		140°			0,538	57			305
		180°			0,693	62			345
4 - 6,8	BVC 130	100°	10.000	190	0,58	59	270	227	267
		140°			0,813	64			305
		180°			1,045	70			345
5 - 7,5	BVC 140	100°	10.900	190	0,696	85	300	250	291
		140°			0,974	94			337
		180°			1,253	103			383
7 - 9	BVC 160	100°	17.500	210	1,147	87	300	266	291
		140°			1,606	95			337
		180°			2,064	104			383
8,5 - 11	BVC 180	100°	19.500	190	1,421	121	320	290	319
		140°			1,989	135			371
		180°			2,557	149			423
10 - 13	BVC 225	100°	36.700	190	1,892	158	382	327	350
		140°			2,649	175			404
		180°			3,226	200			455
12 - 16	BVC 240	100°	40.000	190	2,34	167	382	328	354
		140°			3,281	187			412
15 - 23	BVC 250	100°	47.300	190	2,519	200	350	353	368
		140°			3,527	224			430
22 - 26	BVC 260	100°	53.000	190	3,291	266	450	380	420
		140°			4,61	301			482
25 - 29	BVC 270	100°	63.000	190	3,967	322	490	400	460
		140°			5,554	358			534
28 - 38	BVC 300	100°	90.000	190	5,742	554	495	478	540
		140°			8,039	605			612
37 - 50	BVC 350	100°	100.000	190	7,969	666	608	515	565
		140°			11,187	727			641
48 - 60	BVC 400	100°	140.000	190	12,5	1.240	760	620	675
		140°			17,5	1.426			800
58 - 70	BVC 420	100°	165.000	190	14,322	1.403	800	680	707
		140°			20,04	1.655			835
68 - 100	BVC 450	100°							on request
		140°							

Further sizes available on request ► vertrieb@hks-partner.com

HKS RotoBox • Technical Data

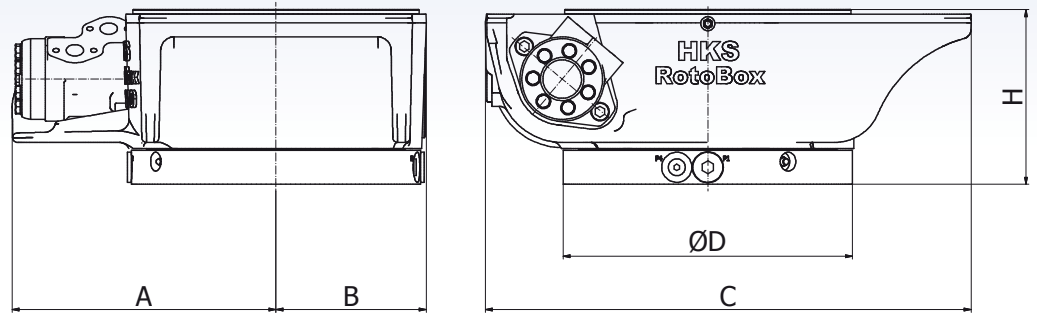

HKS TiltRotator Type		TR 18	TR 35	TR 60	TR 85
Excavator weight (t)		< 1,8	1,8 - 3,5	3 - 6	5 - 8,5
assigned RB with rotary feed system		RB 30	RB 30	RB 60	RB 110
DD	Weight rotary feed system [kg]	7	7	13	24
	Flow rotary feed system at pressure difference $\Delta p=10\text{bar}$ (HLP 46 30°C) [l/min]	42	42	52	130
RotoBox	Weight RB without rotary feed system [kg]	44	44	78	121
	Axial load max. [N]	95.000	95.000	100.000	150.000
	Radial load max. [N]	48.000	48.000	95.000	130.000
	Torque @ 140 bars [Nm]	700	700	1.100	2.300
	Max. rotations/minute @ l/min	8 @ 28 l/min	8 @ 28 l/min	8 @ 28 l/min	8 @ 33 l/min
	Dimensions				
	A [mm]	112	112	237	281
	B [mm]	176	176	133	159
C [mm]	425	425	445	517	
ØD [mm]	180	180	266	308	
H [mm]	134	134	156	177	
XtraTilt BVC-R	assigned BVC-R	BVC-R 90	BVC-R 100	BVC-R 115	BVC-R 130
	Tilt angle	110°	110°	110°	110°
	Displacement	0,288	0,413	0,563	1,227
	Torque @ 210 bar	1.700 Nm	2.600 Nm	3.500 Nm	8.000 Nm
	Holding torque @ 210 bars [Nm]	5.000 Nm	7.500 Nm	11.000 Nm	18.000 Nm
	Weight [kg]	27	35	59	87
TiltRotator	Wieght TR without rotary feed system	71	79	137	208
	Dimensions				
	E [mm]	291	301	364	424
	F [mm]	221	226	272	312
L [mm]	301	353	357	392	

HKS TiltRotator • Technical Data

with XtraTilt BVC-R model

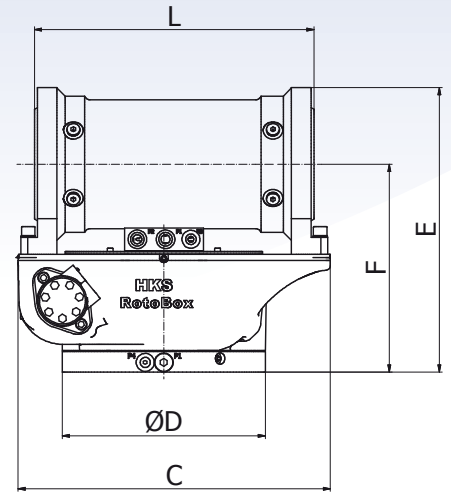
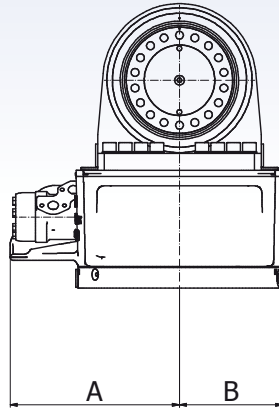

TR 110	TR 180	TR 250	TR 330	TR 450
8 - 11	10 - 18	17 - 25	24 - 33	32 - 45
RB 110	RB 180	RB 250	RB 330	
24	28	46	102	on request
130	160	200	360	
121	173	301	378	
150.000	200.000	400.000	600.000	
130.000	170.000	250.000	350.000	
2.300	2.800	3.800	4.200	
8 @ 33 l/min	8 @ 45 l/min	6 @ 45 l/min	5 @ 45 l/min	
281	300	280	300	
159	183	226	257	
517	554	635	720	
308	360	440	508	
177	209	249	269	
BVC-R 130	BVC-R 180	BVC-R 200	BVC-R 260	
110°	110°	110°	110°	
1,665	2,822	3,598	7,249	
12.000 Nm	15.000 Nm	21.000 Nm	43.000 Nm	
22.000 Nm	38.000 Nm	50.000 Nm	90.000 Nm	
100	155	203	388	
221	328	504	766	
424	505	564	679	
312	369	419	489	
471	496	574	636	



Visit us:
www.hks-partner.com

Inquiry / order code

Please inform us of the order code in your inquiry, either by e-mail, fax or on the telephone.

Used hydraulic excavator / carrier implement used

Manufacturer: Equipment code:

<input type="text"/>	<input type="text"/>	<input type="text"/>	<input type="checkbox"/> yes <input type="checkbox"/> no	<input type="checkbox"/> yes <input type="checkbox"/> no	<input type="checkbox"/> yes <input type="checkbox"/> no	<input type="text"/>	<input type="text"/>	<input type="text"/>	<input type="text"/>
						Manufacturer type of quick-change system			
						mechanical <input type="text"/>			
						hydraulic <input type="text"/>			
						Fixed arm connection to the actuator			
						screwed <input type="text"/>			
						welded <input type="text"/>			
						Load-holding valve recommended for mini-excavators of up to 5 t due to possible leakage in the valves of the hydraulic excavator.			
						Rotary oil joint only for HKS RotoBox and HKS Tiltrotator.			
						Tilt angle BVC: 100° / 140° / 180° TR: 110°			
						Actuator size , e.g.: 240			
						TYPE: BVC / BVC-L / BVC-K / RB / RB-K / TR / TR-K			

Options:

- suitable electronics (EC)
- changeover valve (UV)
- modular design
- biological service media

Notes:

Your address: Company: _____
 Name: _____
 Street: _____
 Postcode: _____
 Tel: _____
 Fax: _____
 E-Mail: _____

Our address: **HKS Dreh-Antriebe GmbH**
 Leipziger Straße 55
 D-63607 Wächtersbach-Aufenau
 Tel +49 (0) 6053 / 6163 - 0
 Fax +49 (0) 6053 / 6163 - 39
 sales@hks-partner.com
 www.hks-partner.com